

# Padlock 4.KDZN.100

## Quick connector 4.600

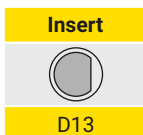
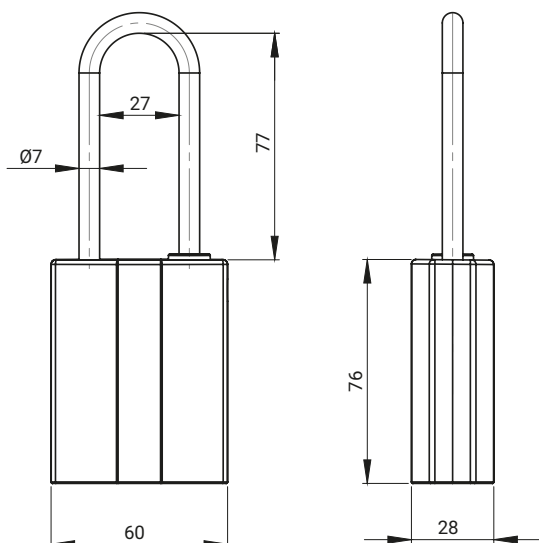

Padlock is equipped with a special shaped insert type D13.

CATALOGUE NO.	COMPONENTS	MATERIAL	FINISH [C]
			RAL9005
4.KDZN.100	Body	ZAMAK 5	04
	Shackle	Steel zinc plated	-

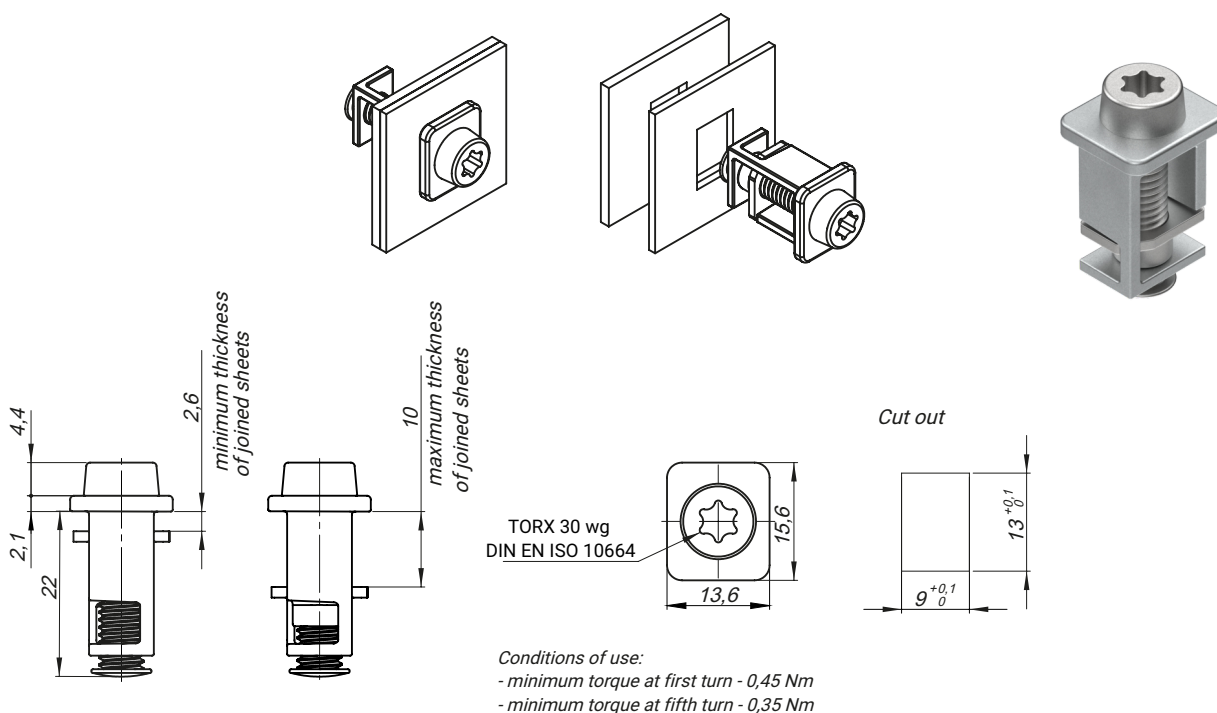

CATALOGUE NO.	COMPONENTS	MATERIAL
4.600.001	Body	Znal zinc plated
	Screw, Nut	Steel zinc plated