

Screw clamps v-klema type Aluminium

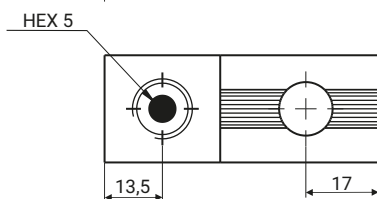

16-120SW

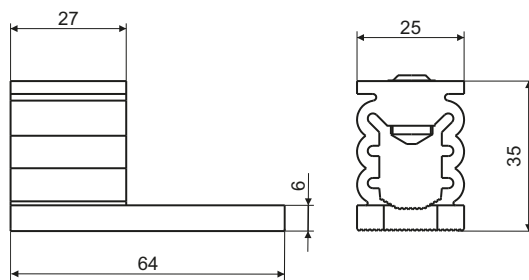

Cross section	Tightening torque
16-35mm ²	12 Nm
50-120mm	25 Nm ²

For the multiwire sector shaped conductor **rm** the need to use the tip of the sleeve DIN 46228/4

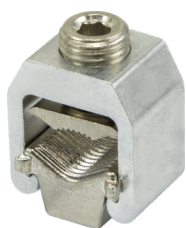

10-150.SW.A

10-150.SW.B

10-150.SW.C1

10-150.SW.C2

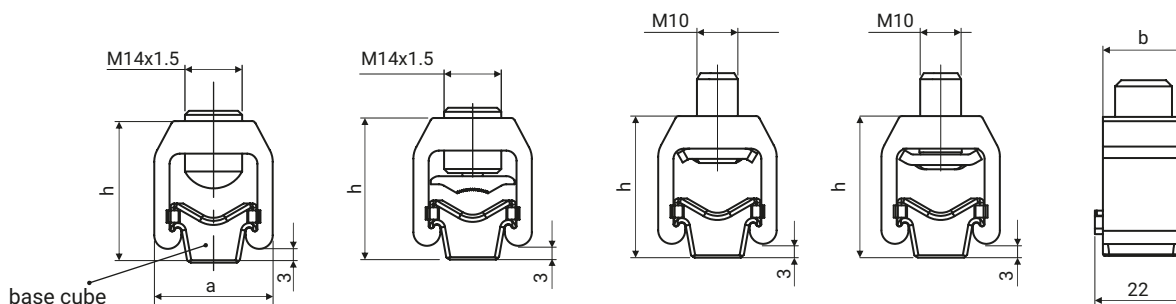

- sm** - multiwire sector shaped conductor (flexible) **rm** - round multiwire conductor (flexible)
- se** - sector shaped conductor (rigid) **re** - round conductor (rigid)

DETAIL	CROSS-SECTION [mm ²]				NOMINAL CROSS-SECTION [mm ²]	MAX TIGHTENING TORQUE [Nm]	DIMENSIONS		
	sm	se	rm	re			a	b	h
16-120SW	-	-	16-120	16-120	120	12-25	25	27	35
10-150.SW.A	35-120	35-150	10-95	10-120	120	15	29	20	34
10-150.SW.B	35-70	35-95	10-50	10-70	95	15	29	20	34
10-150.SW.C	35-70	35-95	10-50	10-70	95	15	29	20	34

	16-120SW	10-150.SW.A	10-150.SW.B	10-150.SW.C1/C2
Clamp	-	-	Brass tin-plated	Spring steel zinc-plated
Base cube	-	Brass tin-plated		
Housing	Aluminium (AlMgSi)			
Screw	Brass tin-plated			Steel zinc-plated

* SW - hexagon head socked.

* Screw clamps conform to EN 60947-7-1 (IEC 60947-7-1)