

All hinge pivot axes are supported by slide bearings

CATALOGUE NO.	MATERIAL
3.ST302.001SN	Stainless steel

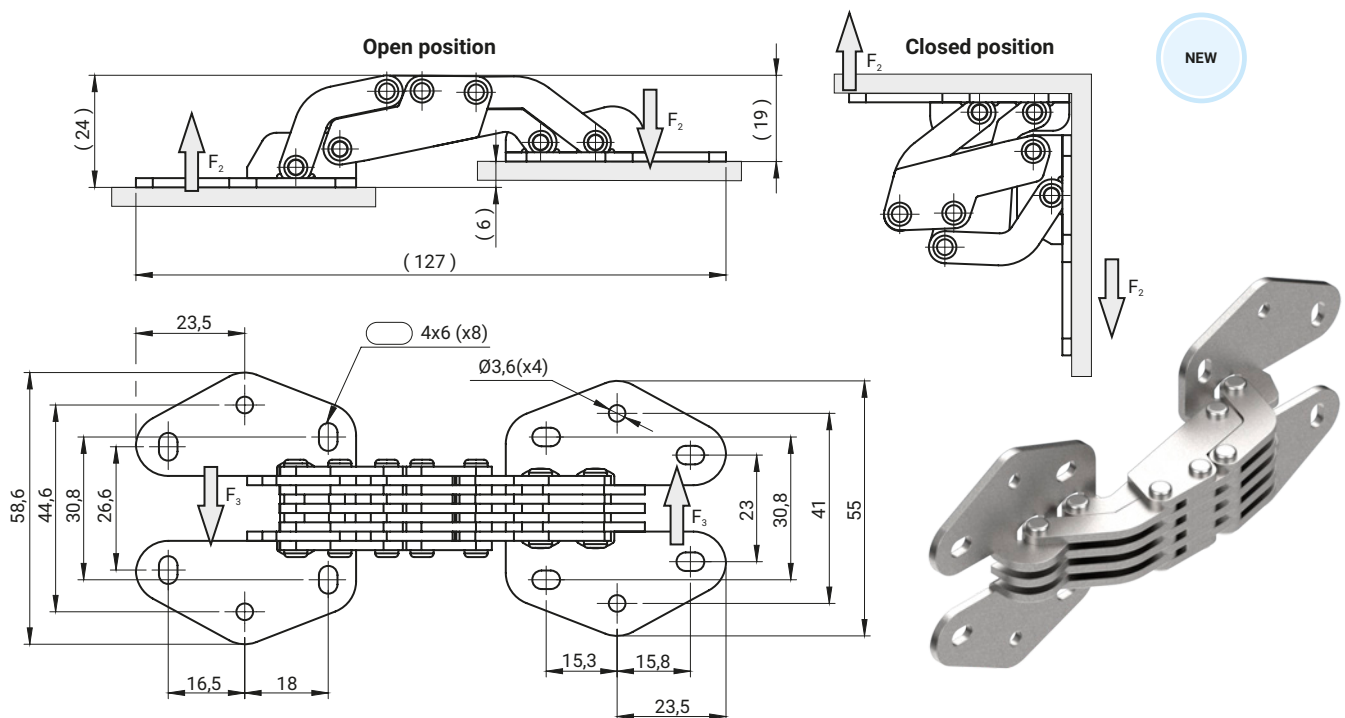

CATALOGUE NO.	MATERIAL
3.ST303.001	Steel zinc plated

The max static load [N]		
Radial force in open position F_1	Radial force in closed position F_2	Axial force F_3
130	580	620

The max static load is the value beyond which the material may break thus prejudicing the hinge performance. Obviously, a suitable coefficient must be applied to this value, according to the importance and the safety level of the specific application.