

3.ZN150.001

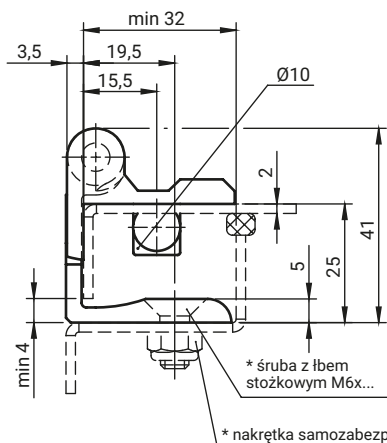

3.ZN150.002

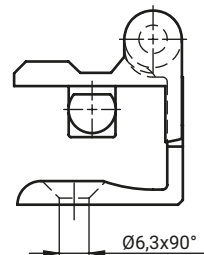

Zawias lewy

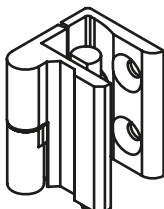

Zawias prawy

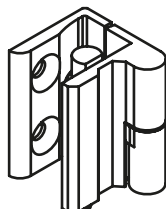

3.ZN150.007

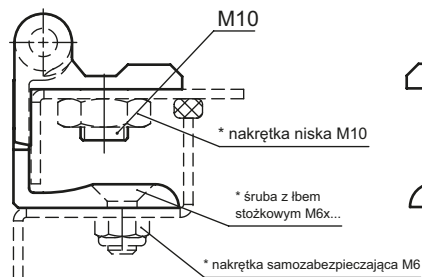

3.ZN150.008

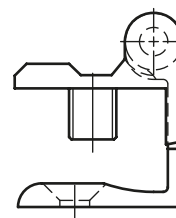

3.ZN150.005

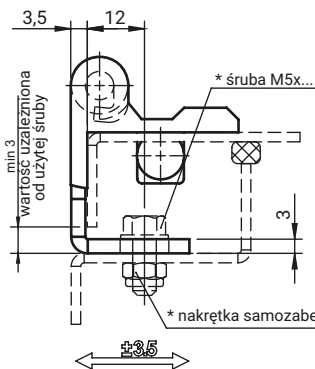

3.ZN150.006

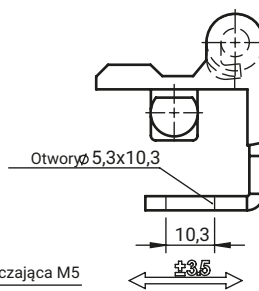

Zawias o kącie otwarcia 180° z blokadą uniemożliwiającą zdjęcie drzwi z szafy przy zamkniętych drzwiach oraz kącie otwarcia drzwi mniejszym niż ~60°

* nie należy do zakresu dostawy

WERSJA	NR KATALOGOWY	ELEMENTY SKŁADOWE	MATERIAŁ	WYKOŃCZENIE [C]
				RAL9005
Prawa	3.ZN150.001 3.ZN150.007	Uchwyt	ZAMAK 5	04
		Stopa	ZAMAK 5	
Lewa	3.ZN150.002 3.ZN150.008	Szpilka	Poliamid	-
		Sworzeń	Stal ocynkowana	
Prawa	3.ZN150.005	Uchwyt	ZAMAK 5	04
		Stopa	Stal	
Lewa	3.ZN150.006	Szpilka	Poliamid	-
		Sworzeń	Stal ocynkowana	