

CATALOGUE NO.	Maximum Working Torque
3.516.001	2.5N.m
3.516.002	0.7N.m

CATALOGUE NO.	COMPONENTS	MATERIAL	FINISH [C]		
			Chrome	RAL9005	RAL7035
3.516.001	Holder, Base	Polyamide	01	04	05
3.516.002	Pin	Polycarbonate	-	-	-

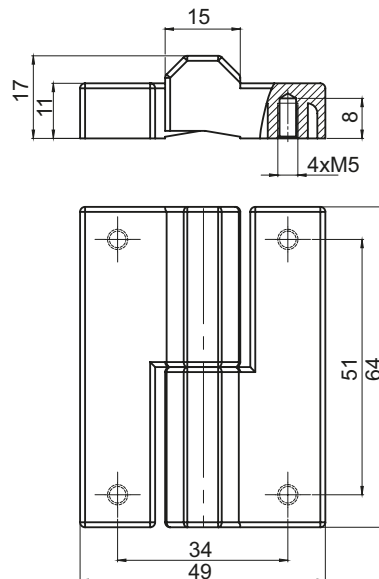

CATALOGUE NO.	VERSION	COMPONENTS	MATERIAL	FINISH [C]		
				Chrome	RAL9005	RAL7035
3.526.001	RIGHTS	Holder, Base	ZAMAK 5	01	04	05
3.526.002	LEFT	Pin	Steel zinc plated	-	-	-

**How to order:**

Catalogue number

Finish

