

CATALOGUE NO.	COMPONENTS	MATERIAL	FINISH [C]
			RAL 9005
2.800.001	Handle	Aluminium	04
	Cam, Base, Grip	Steel zinc plated	-

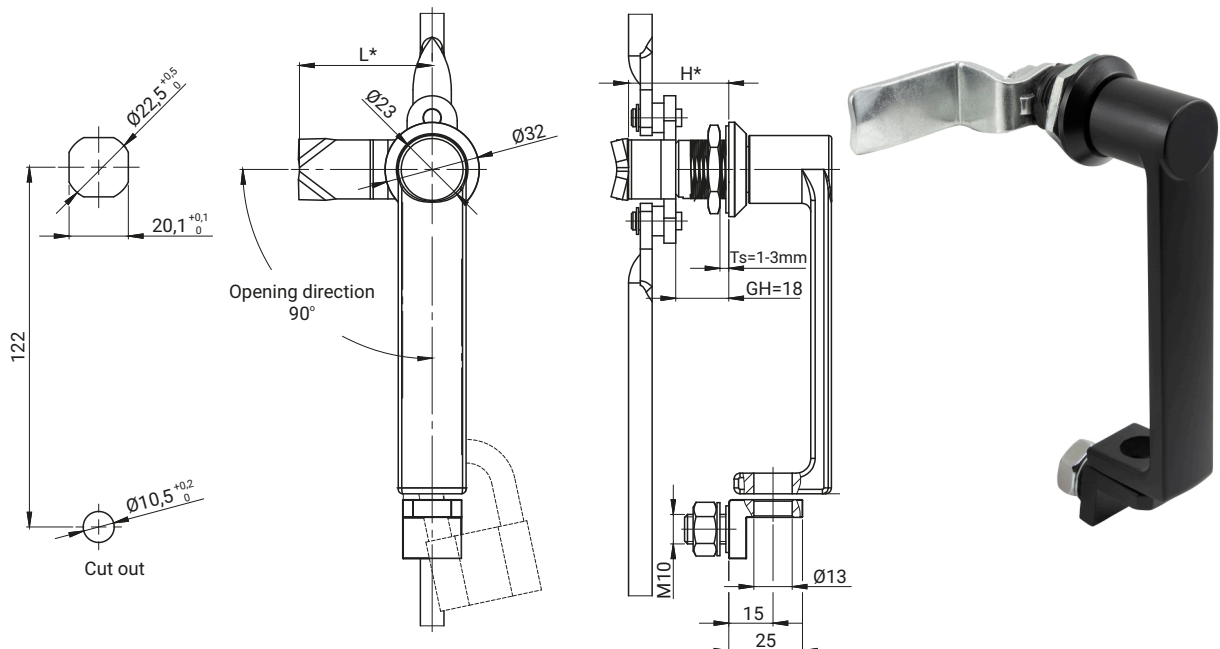

The lock is fitted with cams from the group: 12, 14, 17, 17A, 18, 32, 34, JK1-16018, JK2-16018, J-6000.03, J-6000.04, JK-1610.01, JZ-002 (pg. 1C-10 to 1C-23)
Rods page 1C-4, 1C-5,
Ts - thickness of a metal sheet

CATALOGUE NO.	COMPONENTS	MATERIAL	FINISH [C]
			RAL 9005
2.540.001	Handle, Housing, Blockade	ZAMAK 5	04
	Cam	Zinc plated steel	-