

IP65

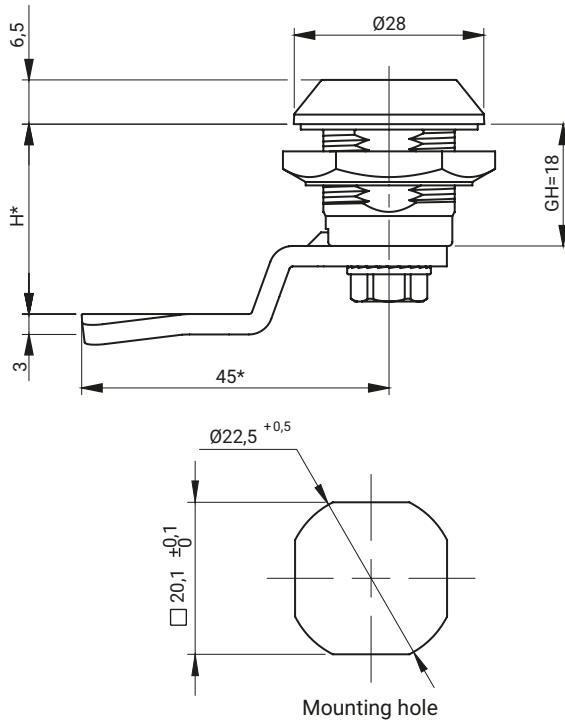

FINISHING TYPE OF THE INSERT AND THE BODY [C]

ZAMAK 5						Polyamide		Stainless steel	
Chrome	Nickel	Galvanized	RAL 9005	RAL 7035	No coating	RAL 9005	RAL 7035	304	316
01	02	03	04	05	00	7	8	9.1	-

THE TYPE OF THE NUT [N]

	ZAMAK 5		Polyamide	Steel	Stainless steel	
					304	316
Nut without grounding	11		12	13	14	15
Nut with grounding	21		-	23	24	25

TYPE OF THE MATERIAL OF THE INSERT	INSERTS [X]										
	D3	D5	T8	T9	KW8	S	N	C9	HEX	T13	T13S
ZAMAK 5	●	●	●	●	●	●	●	●	●	●	●

How to order:

- Type of lock
- Type of body
- Type of insert [X]
- Type of cam
- IP65 class

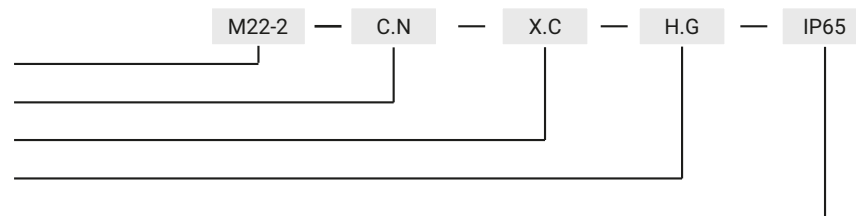

where C,N, G stand for:

- C - type of the material and finishing of the surface
- N - type of nut
- H.G - the cam unbending dimension

Notice:

The lock is fitted with cams from the group: 12, 14, 17, 17A, 18, 32, 34, JK1-16018, JK2-16018, J-6000.03, J-6000.04, JK-1610.01, JZ-002 (pg. 1C-10 to 1C-23)