

LH/RH

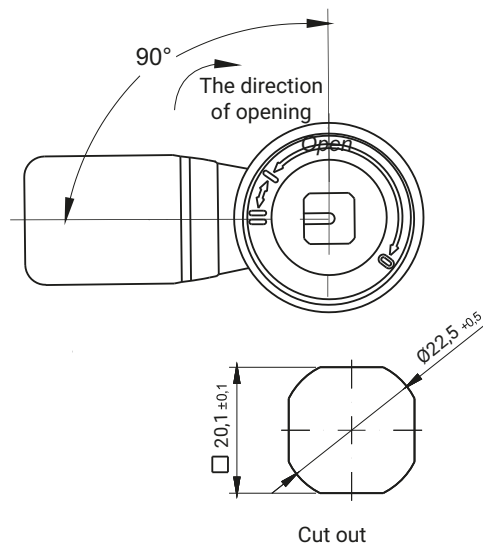

M22SG



M22SG.C

INSERTS [X]		FINISH [C]	
		Chrom	RAL 9005
T9	KW8	01	04

TYPE OF LOCK	COMPONENTS	MATERIAL
M22SG	Housing, insert	ZAMAK 5
M22SG.C	Cam	Steel zinc plated

**How to order:**

Type of lock

Type of insert

Height cam H =24; 27; 30; 33; 36

Finish

Lock version ( P- right, L- left)

\* possibility to make in another dimension

