

Lock M22SC

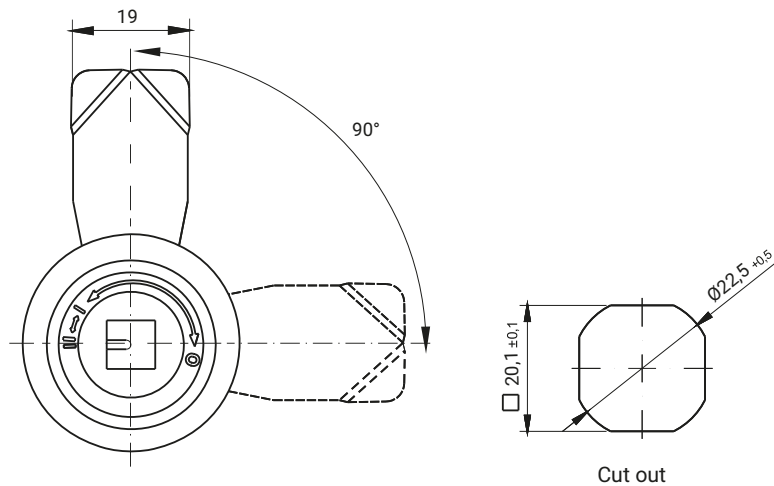
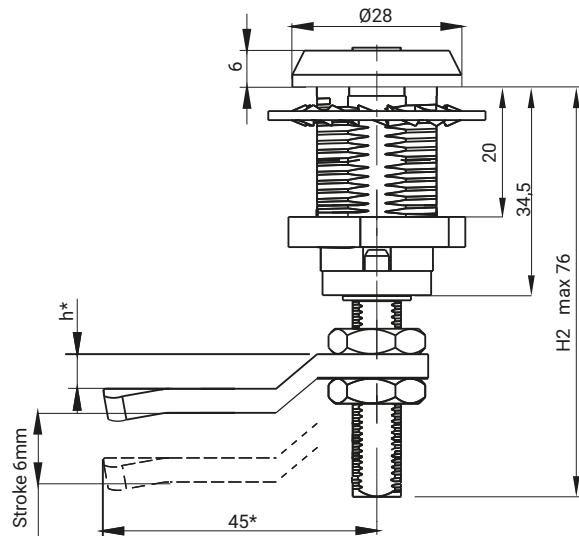
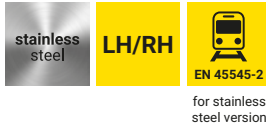

| INSERTS [X] | | | | | FINISH [C] | |
|--------------|-----|---|-----------------|---------|-------------------|--|
| | | | | | Chrome | |
| T9 | KW8 | S | N | RAILWAY | 01 | |
| TYPE OF LOCK | | | COMPONENTS | | MATERIAL | |
| M22SC | | | Housing | | ZAMAK 5 | |
| | | | Insert | | Stainless steel | |
| M22SC SN | | | Cam | | Steel zinc plated | |
| | | | Housing, insert | | Stainless steel | |
| | | | Cam | | | |

How to order:

Type of lock

Type of insert

Height cam $h = 0, 3, 6, 9, -3, -6, -9$

Finish

Lock version (P-right, L-left)

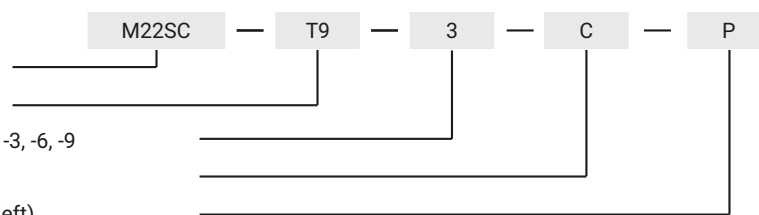

* possibility to make in another dimension