

Lock M22SA18 with foamed sealing PUR

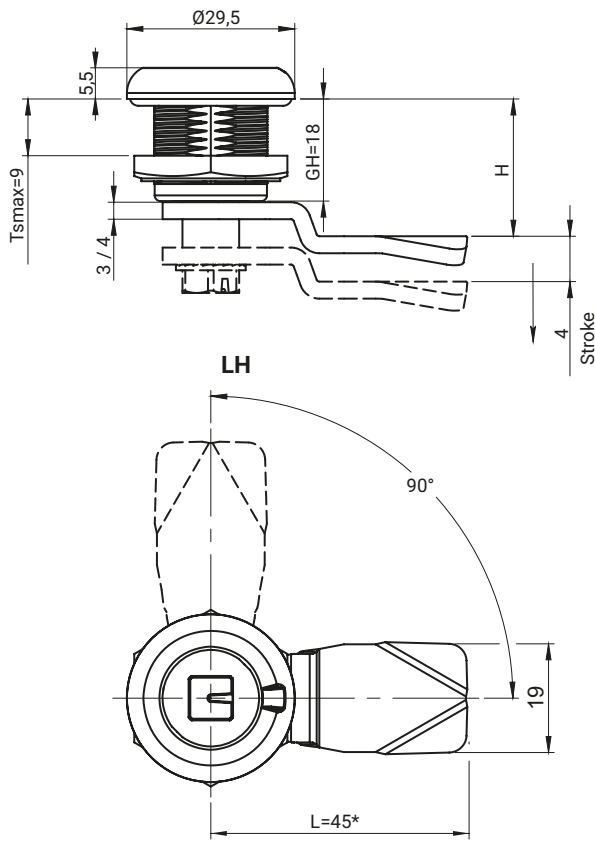

Housing with foamed sealing PUR

TYPE OF LOCK		COMPONENTS		MATERIAL	
M22SA18		Housing, Insert		ZAMAK 5	
INSERTS [X]			FINISH [C]		
			Chrome	RAL9005	
KW8	T8	D5	01	04	

How to order:

- Type of lock
- Type of lock (L-Left)
- Housing finish [C]
- Type of insert [X]
- Insert finish [C]
- Locking height

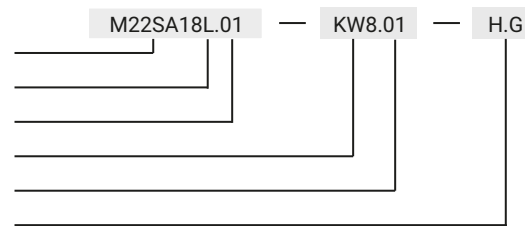

where:

- H - the cam unbending dimension
- G - cam group

The lock is fitted with cams from the group: 15, 16, 19, 21, 35, 36, JK1-10018, JK2-10018, J-6000.01, J-6000.02, JK-1610.01, JZ-001 (pg. 1C-12 to 1C-23)