

IP65

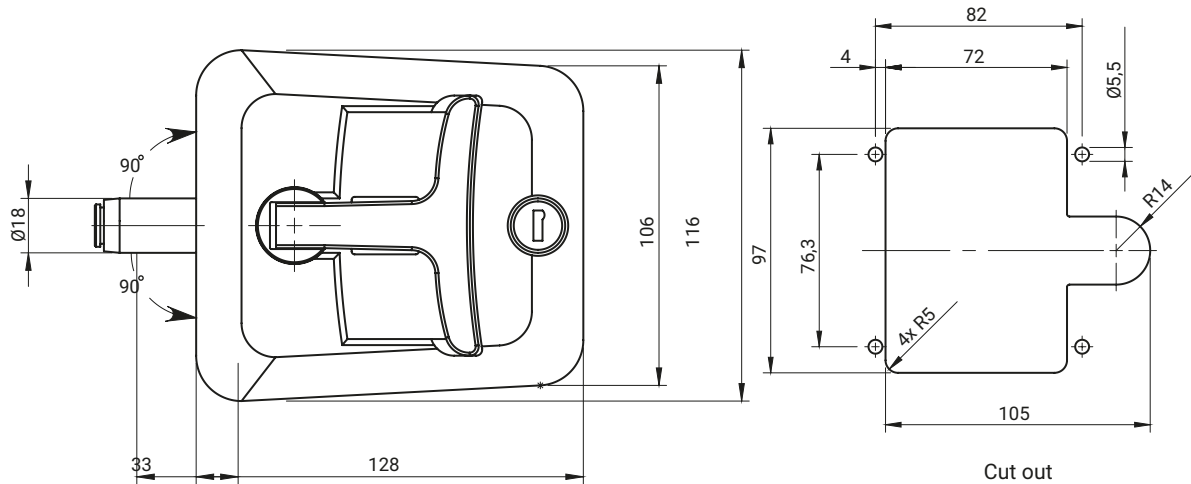
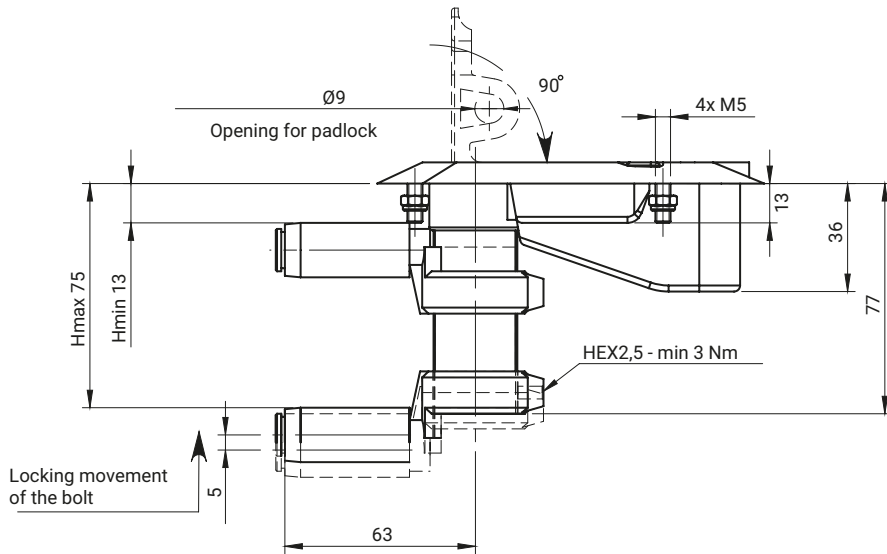

Sealing of the closed door through the axial rotation of the bushing along with the bolt, and fixing the lock in the closed position occurs when the lock handle is folded into its body.
 The position of the bolt (dimension H) is adjustable in the range from 13 to 75 mm.
 The position of the bolt on the bolt bushing is determined during assembly and then fixed with a 2.5 mm HEX key - the minimum recommended tightening torque is 3 Nm.
 The lock handle is available in two colors: black (RAL 9005) and grey (RAL 7035).

CATALOGUE NO.	COMPONENTS	MATERIAL	FINISH [C]	
			RAL9005	RAL7035
2.515.001	Housing, Lever Roller	Polyamide PA6 GF	07	-
	Handle	ZAMAK 5	04	05
	Bolt, Lever Bushing	ZAMAK 5	-	-

How to order:

Catalogue no.
 Housing finish
 Handle finish

