

GH - wysokość korpusu  
H - wysokość ryglowania  
h - wysokość języka  
L - długość języka  
g - grubość języka

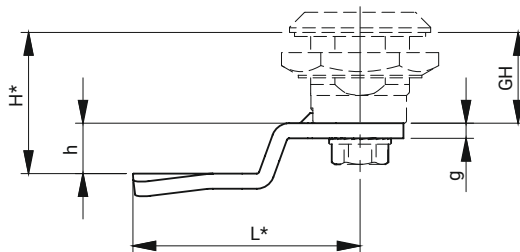

### Języki 1- pkt z ogranicznikiem

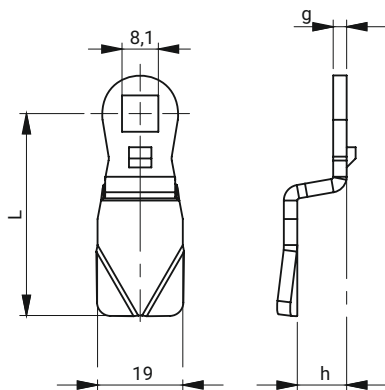
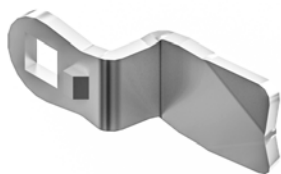

### Języki 1- pkt bez ogranicznika

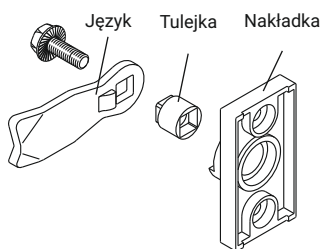
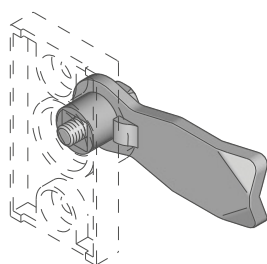
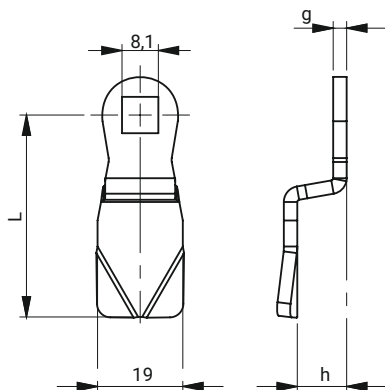
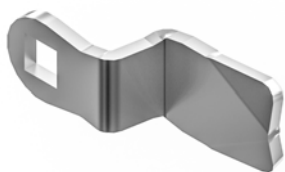

**UWAGA:**  
Przy zamawianiu języka 1-pkt z ogranicznikiem do nakładki bezwzględnie należy zamówić tulejkę str. 1C-27

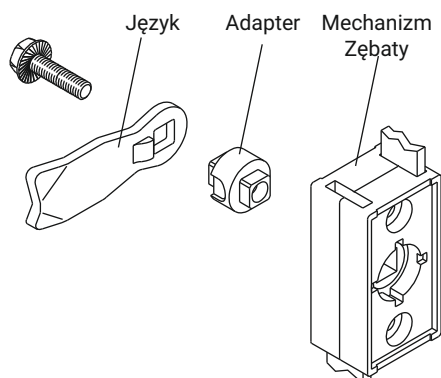
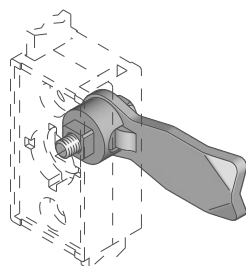

**UWAGA:**  
Przy zamawianiu języka 1-pkt z ogranicznikiem do mechanizmu zębatego bezwzględnie należy zamówić adapter str. 1C-27

## STEEL ZINC PLATED

11	APPLICATION: LOCKING SYSTEM WITH CAP AND LOCKS M22													
	H	CATALOGUE NO.	g*	h	L	GH:18 H	GH:19 H	GH:23 H	GH:28 H	GH:30 H	GH:38 H	GH:40 H	GH:50 H	GH:60 H
CAM RANGE [G]	18	J-1751845	3	0	45	18	19	23	28	30	38	40	50	60
	19	J-1751945	3	1	45	19	20	24	29	31	39	41	51	61
	20	J-1752045	3	2	45	20	21	25	30	32	40	42	52	62
	21	J-1752145	3	3	45	21	22	26	31	33	41	43	53	63
	22	J-1752245	3	4	45	22	23	27	32	34	42	44	54	64
	24	J-1752445	3	6	45	24	25	29	34	36	44	46	56	66
	26	J-1752645	3	8	45	26	27	31	36	38	46	48	58	68
	28	J-1752845	3	10	45	28	29	33	38	40	48	50	60	70
	30	J-1753045	3	12	45	30	31	35	40	42	50	52	62	72
	32	J-1753245	3	14	45	32	33	37	42	44	52	54	64	74
	34	J-1753445	3	16	45	34	35	39	44	46	54	56	66	76
	36	J-1753645	3	18	45	36	37	-	46	48	56	58	68	78
	38	J-1753845	3	20	45	38	39	-	48	50	58	60	70	80
	40	J-1754045	3	22	45	40	41	-	50	52	60	62	72	82
	42	J-1754245	3	24	45	42	43	-	52	54	62	64	74	84
	16	J-1751645	3	-2	45	16	17	-	26	28	36	38	48	58
	14	J-1751445	3	-4	45	14	15	-	24	26	34	36	46	56
	12	J-1751245	3	-6	45	12	13	-	22	24	32	34	44	54
10	J-1751045	3	-8	45	10	11	-	20	22	30	32	42	52	
8	J-1750845	3	-10	45	8	9	-	18	20	28	30	40	50	

1C | Locking systems components

2 | Locks | Latches

3 | Hinges

4 | Screw clamps

12	APPLICATION: LOCKS M22													
	H	CATALOGUE NO.	g*	h	L	GH:18 H	GH:19 H	GH:23 H	GH:28 H	GH:30 H	GH:38 H	GH:40 H	GH:50 H	GH:60 H
CAM RANGE [G]	18	J-1601845	3	0	45	18	19	23	28	30	38	40	50	60
	19	J-1601945	3	1	45	19	20	24	29	31	39	41	51	61
	20	J-1602045	3	2	45	20	21	25	30	32	40	42	52	62
	21	J-1602145	3	3	45	21	22	26	31	33	41	43	53	63
	22	J-1602245	3	4	45	22	23	27	32	34	42	44	54	64
	24	J-1602445	3	6	45	24	25	29	34	36	44	46	56	66
	26	J-1602645	3	8	45	26	27	31	36	38	46	48	58	68
	28	J-1602845	3	10	45	28	29	33	38	40	48	50	60	70
	30	J-1603045	3	12	45	30	31	35	40	42	50	52	62	72
	32	J-1603245	3	14	45	32	33	37	42	44	52	54	64	74
	34	J-1603445	3	16	45	34	35	39	44	46	54	56	66	76
	36	J-1603645	3	18	45	36	37	-	46	48	56	58	68	78
	38	J-1603845	3	20	45	38	39	-	48	50	58	60	70	80
	40	J-1604045	3	22	45	40	41	-	50	52	60	62	72	82
	42	J-1604245	3	24	45	42	43	-	52	54	62	64	74	84
	16	J-1601645	3	-2	45	16	17	-	26	28	36	38	48	58
	14	J-1601445	3	-4	45	14	15	-	24	26	34	36	46	56
	12	J-1601245	3	-6	45	12	13	-	22	24	32	34	44	54
10	J-1601045	3	-8	45	10	11	-	20	22	30	32	42	52	
8	J-1600845	3	-10	45	8	9	-	28	20	28	30	40	50	

5 | Accessories

6 | Gasketing profiles

7 | Custom products

When ordering a custom cam, you should contact your dealer for more details .

## STAL NIERDZEWNA

13	ZASTOSOWANIE: SYSTEMY ZAMYKANIA Z NAKŁADKĄ ORAZ ZAMKI M22													
	H	NUMER KATALOGOWY	g*	h	L	GH:18 H	GH:19 H	GH:23 H	GH:28 H	GH:30 H	GH:38 H	GH:40 H	GH:50 H	GH:60 H
GRUPA JĘZYKÓW [G]	18	J-1751845SN	3	0	45	18	19	23	28	30	38	40	50	60
	19	J-1751945SN	3	1	45	19	20	24	29	31	39	41	51	61
	20	J-1752045SN	3	2	45	20	21	25	30	32	40	42	52	62
	21	J-1752145SN	3	3	45	21	22	26	31	33	41	43	53	63
	22	J-1752245SN	3	4	45	22	23	27	32	34	42	44	54	64
	24	J-1752445SN	3	6	45	24	25	29	34	36	44	46	56	66
	26	J-1752645SN	3	8	45	26	27	31	36	38	46	48	58	68
	28	J-1752845SN	3	10	45	28	29	33	38	40	48	50	60	70
	30	J-1753045SN	3	12	45	30	31	35	40	42	50	52	62	72
	32	J-1753245SN	3	14	45	32	33	37	42	44	52	54	64	74
	34	J-1753445SN	3	16	45	34	35	39	44	46	54	56	66	76
	36	J-1753645SN	3	18	45	36	37	-	46	48	56	58	68	78
	38	J-1753845SN	3	20	45	38	39	-	48	50	58	60	70	80
	40	J-1754045SN	3	22	45	40	41	-	50	52	60	62	72	82
	42	J-1754245SN	3	24	45	42	43	-	52	54	62	64	74	84
	16	J-1751645SN	3	-2	45	16	17	-	26	28	36	38	48	58
	14	J-1751445SN	3	-4	45	14	15	-	24	26	34	36	46	56
	12	J-1751245SN	3	-6	45	12	13	-	22	24	32	34	44	54
10	J-1751045SN	3	-8	45	10	11	-	20	22	30	32	42	52	
8	J-1750845SN	3	-10	45	8	9	-	28	20	28	30	40	50	

14	ZASTOSOWANIE: ZAMKI M22													
	H	NUMER KATALOGOWY	g*	h	L	GH:18 H	GH:19 H	GH:23 H	GH:28 H	GH:30 H	GH:38 H	GH:40 H	GH:50 H	GH:60 H
GRUPA JĘZYKÓW [G]	18	J-1601845SN	3	0	45	18	19	23	28	30	38	40	50	60
	19	J-1601945SN	3	1	45	19	20	24	29	31	39	41	51	61
	20	J-1602045SN	3	2	45	20	21	25	30	32	40	42	52	62
	21	J-1602145SN	3	3	45	21	22	26	31	33	41	43	53	63
	22	J-1602245SN	3	4	45	22	23	27	32	34	42	44	54	64
	24	J-1602445SN	3	6	45	24	25	29	34	36	44	46	56	66
	26	J-1602645SN	3	8	45	26	27	31	36	38	46	48	58	68
	28	J-1602845SN	3	10	45	28	29	33	38	40	48	50	60	70
	30	J-1603045SN	3	12	45	30	31	35	40	42	50	52	62	72
	32	J-1603245SN	3	14	45	32	33	37	42	44	52	54	64	74
	34	J-1603445SN	3	16	45	34	35	39	44	46	54	56	66	76
	36	J-1603645SN	3	18	45	36	37	-	46	48	56	58	68	78
	38	J-1603845SN	3	20	45	38	39	-	48	50	58	60	70	80
	40	J-1604045SN	3	22	45	40	41	-	50	52	60	62	72	82
	42	J-1604245SN	3	24	45	42	43	-	52	54	62	64	74	84
	16	J-1601645SN	3	-2	45	16	17	-	26	28	36	38	48	58
	14	J-1601445SN	3	-4	45	14	15	-	24	26	34	36	46	56
	12	J-1601245SN	3	-6	45	12	13	-	22	24	32	34	44	54
10	J-1601045SN	3	-8	45	10	11	-	20	22	30	32	42	52	
8	J-1600845SN	3	-10	45	8	9	-	28	20	28	30	40	50	

W przypadku zamówienia języka niestandardowego należy skontaktować się ze sprzedawcą w celu ustalenia szczegółów.

**STAL OCYNKOWANA**

17	ZASTOSOWANIE: ZAMKI M22													
	H	NUMER KATALOGOWY	g*	h	L	GH:18 H	GH:19 H	GH:23 H	GH:28 H	GH:30 H	GH:38 H	GH:40 H	GH:50 H	GH:60 H
GRUPA JĘZYKÓW [G]	18	J-1651845	3	0	45	18	19	23	28	30	38	40	50	60
	19	J-1651945	3	1	45	19	20	24	29	31	39	41	51	61
	20	J-1652045	3	2	45	20	21	25	30	32	40	42	52	62
	21	J-1652145	3	3	45	21	22	26	31	33	41	43	53	63
	22	J-1652245	3	4	45	22	23	27	32	34	42	44	54	64
	24	J-1652445	3	6	45	24	25	29	34	36	44	46	56	66
	26	J-1652645	3	8	45	26	27	31	36	38	46	48	58	68
	28	J-1652845	3	10	45	28	29	33	38	40	48	50	60	70
	30	J-1653045	3	12	45	30	31	35	40	42	50	52	62	72
	32	J-1653245	3	14	45	32	33	37	42	44	52	54	64	74
	34	J-1653445	3	16	45	34	35	39	44	46	54	56	66	76
	36	J-1653645	3	18	45	36	37	-	46	48	56	58	68	78
	38	J-1653845	3	20	45	38	39	-	48	50	58	60	70	80
	40	J-1654045	3	22	45	40	41	-	50	52	60	62	72	82
	42	J-1654245	3	24	45	42	43	-	52	54	62	64	74	84
	16	J-1651645	3	-2	45	16	17	-	26	28	36	38	48	58
	14	J-1651445	3	-4	45	14	15	-	24	26	34	36	46	56
	12	J-1651245	3	-6	45	12	13	-	22	24	32	34	44	54
10	J-1651045	3	-8	45	10	11	-	20	22	30	32	42	52	
8	J-1650845	3	-10	45	8	9	-	28	20	28	30	40	50	

**STAL NIERDZEWNA**

17A	ZASTOSOWANIE: ZAMKI M22													
	H	NUMER KATALOGOWY	g*	h	L	GH:18 H	GH:19 H	GH:23 H	GH:28 H	GH:30 H	GH:38 H	GH:40 H	GH:50 H	GH:60 H
GRUPA JĘZYKÓW [G]	18	J-1651845SN	3	0	45	18	19	23	28	30	38	40	50	60
	19	J-1651945SN	3	1	45	19	20	24	29	31	39	41	51	61
	20	J-1652045SN	3	2	45	20	21	25	30	32	40	42	52	62
	21	J-1652145SN	3	3	45	21	22	26	31	33	41	43	53	63
	22	J-1652245SN	3	4	45	22	23	27	32	34	42	44	54	64
	24	J-1652445SN	3	6	45	24	25	29	34	36	44	46	56	66
	26	J-1652645SN	3	8	45	26	27	31	36	38	46	48	58	68
	28	J-1652845SN	3	10	45	28	29	33	38	40	48	50	60	70
	30	J-1653045SN	3	12	45	30	31	35	40	42	50	52	62	72
	32	J-1653245SN	3	14	45	32	33	37	42	44	52	54	64	74
	34	J-1653445SN	3	16	45	34	35	39	44	46	54	56	66	76
	36	J-1653645SN	3	18	45	36	37	-	46	48	56	58	68	78
	38	J-1653845SN	3	20	45	38	39	-	48	50	58	60	70	80
	40	J-1654045SN	3	22	45	40	41	-	50	52	60	62	72	82
	42	J-1654245SN	3	24	45	42	43	-	52	54	62	64	74	84
	16	J-1651645SN	3	-2	45	16	17	-	26	28	36	38	48	58
	14	J-1651445SN	3	-4	45	14	15	-	24	26	34	36	46	56
	12	J-1651245SN	3	-6	45	12	13	-	22	24	32	34	44	54
10	J-1651045SN	3	-8	45	10	11	-	20	22	30	32	42	52	
8	J-1650845SN	3	-10	45	8	9	-	28	20	28	30	40	50	