

GH - height body
H - height locking
h - height cam
L - length cam
g - thickness cam

3-point CAM with limiter

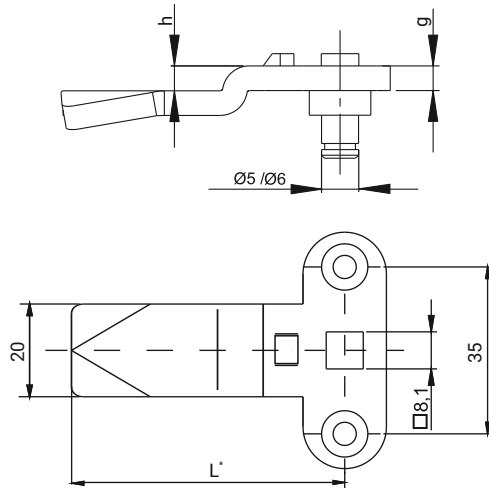

3-point CAM without limiter

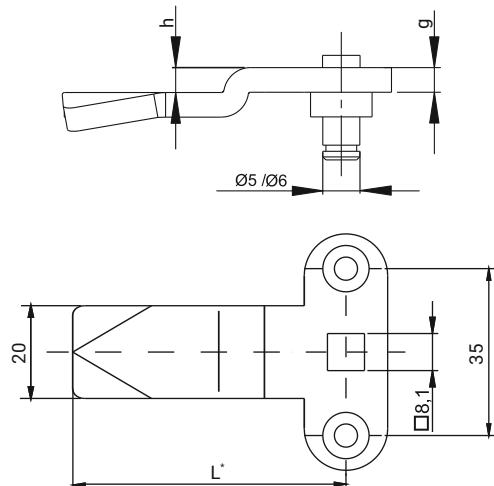

STEEL ZINC PLATED

31

APPLICATION: LOCKING SYSTEM WITH CAP AND LOCKS M22

H	CATALOGUE NUMBER	g*	h	L	GH:18 H	GH:19 H	GH:23 H	GH:28 H	GH:30 H	GH:38 H	GH:40 H	GH:50 H	GH:60 H
18	J-3751845	3	0	45	18	19	23	28	30	38	40	50	60
19	J-3751945	3	1	45	19	20	24	29	31	39	41	51	61
20	J-3752045	3	2	45	20	21	25	30	32	40	42	52	62
21	J-3752145	3	3	45	21	22	26	31	33	41	43	53	63
22	J-3752245	3	4	45	22	23	27	32	34	42	44	54	64
24	J-3752445	3	6	45	24	25	29	34	36	44	46	56	66
26	J-3752645	3	8	45	26	27	31	36	38	46	48	58	68
28	J-3752845	3	10	45	28	29	33	38	40	48	50	60	70
30	J-3753045	3	12	45	30	31	35	40	42	50	52	62	72
32	J-3753245	3	14	45	32	33	37	42	44	52	54	64	74
34	J-3753445	3	16	45	34	35	39	44	46	54	56	66	76
36	J-3753645	3	18	45	36	37	-	46	48	56	58	68	78
38	J-3753845	3	20	45	38	39	-	48	50	58	60	70	80
40	J-3754045	3	22	45	40	41	-	50	52	60	62	72	82
42	J-3754245	3	24	45	42	43	-	52	54	62	64	74	84
16	J-3751645	3	-2	45	16	17	-	26	28	36	38	48	58
14	J-3751445	3	-4	45	14	15	-	24	26	34	36	46	56
12	J-3751245	3	-6	45	12	13	-	22	24	32	34	44	54
10	J-3751045	3	-8	45	10	11	-	20	22	30	32	42	52

32

APPLICATION: LOCKS M22

H	CATALOGUE NUMBER	g*	h	L	GH:18 H	GH:19 H	GH:23 H	GH:28 H	GH:30 H	GH:38 H	GH:40 H	GH:50 H	GH:60 H
18	J-3601845	3	0	45	18	19	23	28	30	38	40	50	60
19	J-3601945	3	1	45	19	20	24	29	31	39	41	51	61
20	J-3602045	3	2	45	20	21	25	30	32	40	42	52	62
21	J-3602145	3	3	45	21	22	26	31	33	41	43	53	63
22	J-3602245	3	4	45	22	23	27	32	34	42	44	54	64
24	J-3602445	3	6	45	24	25	29	34	36	44	46	56	66
26	J-3602645	3	8	45	26	27	31	36	38	46	48	58	68
28	J-3602845	3	10	45	28	29	33	38	40	48	50	60	70
30	J-3603045	3	12	45	30	31	35	40	42	50	52	62	72
32	J-3603245	3	14	45	32	33	37	42	44	52	54	64	74
34	J-3603445	3	16	45	34	35	39	44	46	54	56	66	76
36	J-3603645	3	18	45	36	37	-	46	48	56	58	68	78
38	J-3603845	3	20	45	38	39	-	48	50	58	60	70	80
40	J-3604045	3	22	45	40	41	-	50	52	60	62	72	82
42	J-3604245	3	24	45	42	43	-	52	54	62	64	74	84
16	J-3601645	3	-2	45	16	17	-	26	28	36	38	48	58
14	J-3601445	3	-4	45	14	15	-	24	26	34	36	46	56
12	J-3601245	3	-6	45	12	13	-	22	24	32	34	44	54
10	J-3601045	3	-8	45	10	11	-	20	22	30	32	42	52

When ordering a custom cam, you should contact your dealer for more details ..

STAINLESS STEEL

33	APPLICATION: LOCKING SYSTEM WITH CAP AND LOCKS M22													
	H	CATALOGUE NUMBER	g*	h	L	GH:18 H	GH:19 H	GH:23 H	GH:28 H	GH:30 H	GH:38 H	GH:40 H	GH:50 H	GH:60 H
CAM RANGE [G]	18	J-3751845SN	3	0	45	18	19	23	28	30	38	40	50	60
	19	J-3751945SN	3	1	45	19	20	24	29	31	39	41	51	61
	20	J-3752045SN	3	2	45	20	21	25	30	32	40	42	52	62
	21	J-3752145SN	3	3	45	21	22	26	31	33	41	43	53	63
	22	J-3752245SN	3	4	45	22	23	27	32	34	42	44	54	64
	24	J-3752445SN	3	6	45	24	25	29	34	36	44	46	56	66
	26	J-3752645SN	3	8	45	26	27	31	36	38	46	48	58	68
	28	J-3752845SN	3	10	45	28	29	33	38	40	48	50	60	70
	30	J-3753045SN	3	12	45	30	31	35	40	42	50	52	62	72
	32	J-3753245SN	3	14	45	32	33	37	42	44	52	54	64	74
	34	J-3753445SN	3	16	45	34	35	39	44	46	54	56	66	76
	36	J-3753645SN	3	18	45	36	37	-	46	48	56	58	68	78
	38	J-3753845SN	3	20	45	38	39	-	48	50	58	60	70	80
	40	J-3754045SN	3	22	45	40	41	-	50	52	60	62	72	82
	42	J-3754245SN	3	24	45	42	43	-	52	54	62	64	74	84
	16	J-3751645SN	3	-2	45	16	17	-	26	28	36	38	48	58
	14	J-3751445SN	3	-4	45	14	15	-	24	26	34	36	46	56
	12	J-3751245SN	3	-6	45	12	13	-	22	24	32	34	44	54
10	J-3751045SN	3	-8	45	10	11	-	20	22	30	32	42	52	
8	J-3750845SN	3	-10	45	8	9	-	28	20	28	30	40	50	

34	APPLICATION: LOCKS M22													
	H	CATALOGUE NUMBER	g*	h	L	GH:18 H	GH:19 H	GH:23 H	GH:28 H	GH:30 H	GH:38 H	GH:40 H	GH:50 H	GH:60 H
CAM RANGE [G]	18	J-3601845SN	3	0	45	18	19	23	28	30	38	40	50	60
	19	J-3601945SN	3	1	45	19	20	24	29	31	39	41	51	61
	20	J-3602045SN	3	2	45	20	21	25	30	32	40	42	52	62
	21	J-3602145SN	3	3	45	21	22	26	31	33	41	43	53	63
	22	J-3602245SN	3	4	45	22	23	27	32	34	42	44	54	64
	24	J-3602445SN	3	6	45	24	25	29	34	36	44	46	56	66
	26	J-3602645SN	3	8	45	26	27	31	36	38	46	48	58	68
	28	J-3602845SN	3	10	45	28	29	33	38	40	48	50	60	70
	30	J-3603045SN	3	12	45	30	31	35	40	42	50	52	62	72
	32	J-3603245SN	3	14	45	32	33	37	42	44	52	54	64	74
	34	J-3603445SN	3	16	45	34	35	39	44	46	54	56	66	76
	36	J-3603645SN	3	18	45	36	37	-	46	48	56	58	68	78
	38	J-3603845SN	3	20	45	38	39	-	48	50	58	60	70	80
	40	J-3604045SN	3	22	45	40	41	-	50	52	60	62	72	82
	42	J-3604245SN	3	24	45	42	43	-	52	54	62	64	74	84
	16	J-3601645SN	3	-2	45	16	17	-	26	28	36	38	48	58
	14	J-3601445SN	3	-4	45	14	15	-	24	26	34	36	46	56
	12	J-3601245SN	3	-6	45	12	13	-	22	24	32	34	44	54
10	J-3601045SN	3	-8	45	10	11	-	20	22	30	32	42	52	
8	J-3600845SN	3	-10	45	8	9	-	28	20	28	30	40	50	

When ordering a custom cam, you should contact your dealer for more details ..