

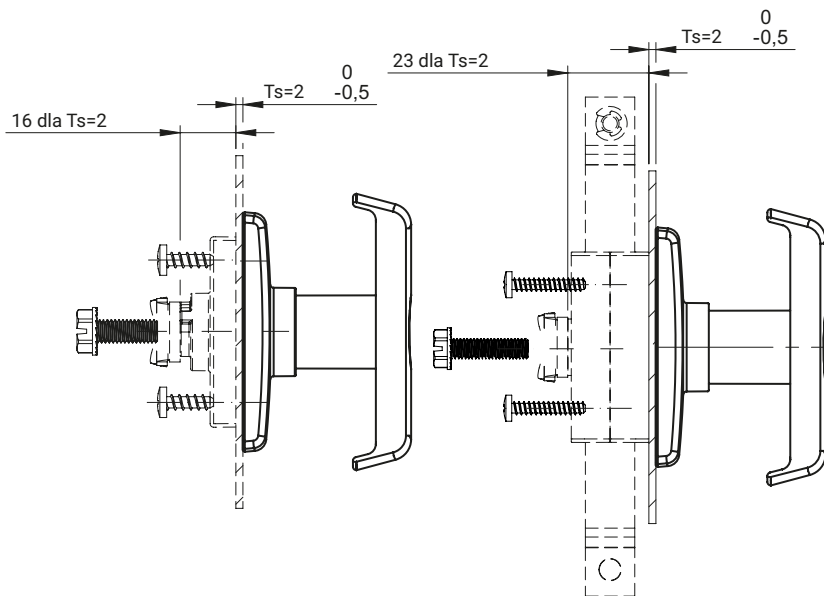

IP65

T-HANDLE LOCK RW515



RW515.N
(Used with Cap)

RW515.M
(Used with Cogwheel mechanism)

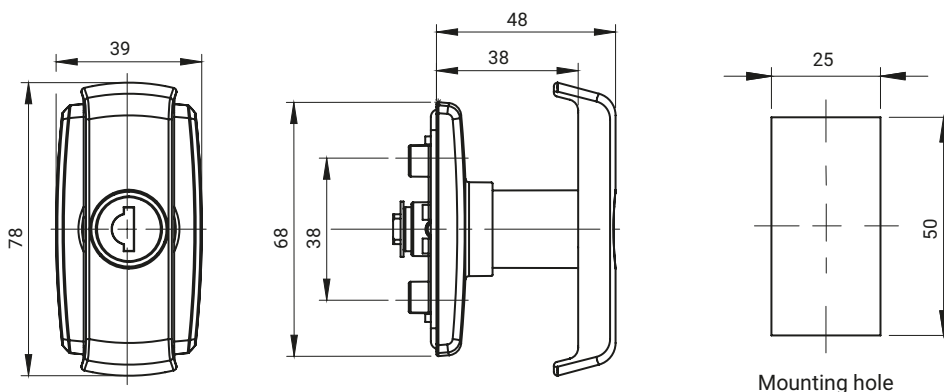

TYPE OF LOCK	COMPONENTS	MATERIAL	FINISH [C]		CYLINDER PROFILE	
			RAL 9005		KEY CODE	NO CYLINDER
RW515.N RW515.M	Housing	Polyamide Pa6 Gf30	07		1333 RK (different code)	BW

How to order:

Type of lock
Finish [C]
Key code

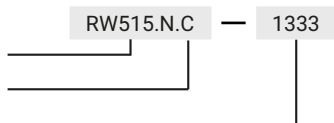

where:
Ts - door thickness

NOTE:

Elements ordered separately for the version for the cover plate and the gear mechanism are included in the tables, see page 1B-51.