

RW210.N
(Used with Cap)

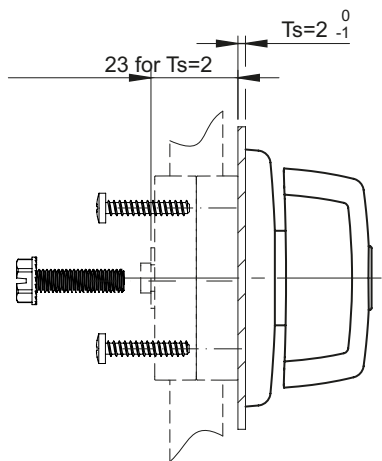

RW210.M
(Used with Cogwheel mechanism)

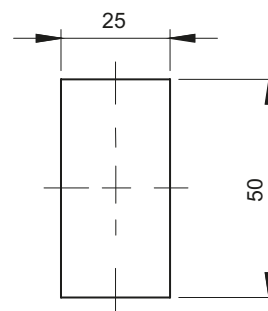

Mounting hole

TYPE OF LOCK	COMPONENTS	MATERIAL	FINISH [C]	CYLINDER PROFILE		
			RAL 9005	KEY CODE	NO CYLINDER	
RW210.N RW210.M	Housing	Polyamide Pa6 Gf30	07	1333	RK (different code)	BW

How to order:

Type of lock
Finish [C]
Key code

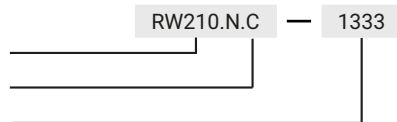

where:

Ts - door thickness

NOTE:

Elements ordered separately for the version for the cover plate and the gear mechanism are included in the tables, see page 1B-50.