



RS170

RS169B

RS170

RS169B

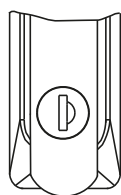
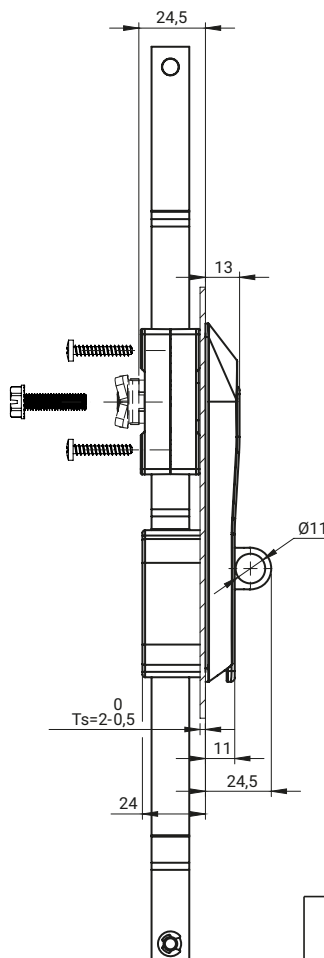
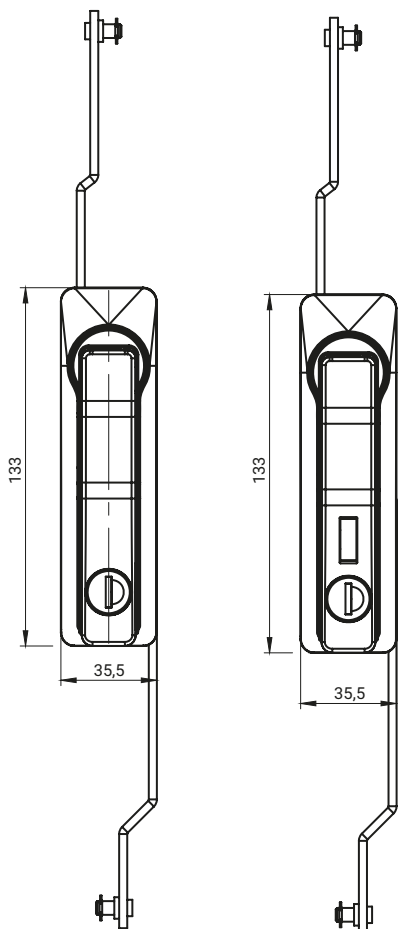

Version A

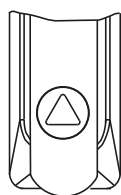

Version B

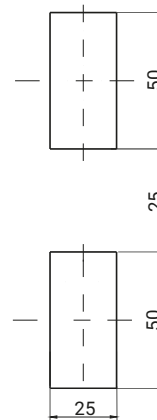

Mounting hole

TYPE OF LOCK	COMPONENTS	MATERIAL	VERSION		FINISH [C]
					RAL 9005
RS169B RS170	Body, Handle	ZAMAK 5	A	B	04

**How to order:**

Type of lock  
Lock version  
Finish

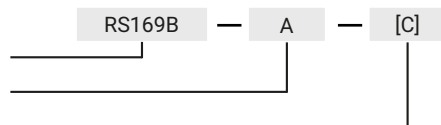

Handle supplied as a complete set under gear mechanism.  
Further components to be ordered separately:

- Cam 1 point (groups: 11,13) ..... pg.: 1C-10, 1C-11
- Flat bars ..... pg.: 1C-34 to 1C-40

where:

Ts - mounting plate thickness