

Mounting hole

TYPE OF LOCK	COMPONENTS	MATERIAL	FINISH [C]	
			RAL9005	RAL7035
RS300.N RS300.M	Body, Handle,	Polyamide PA6 GF30	07	08

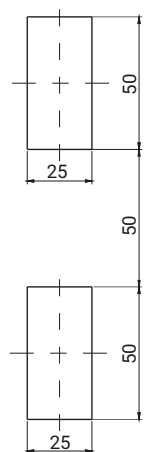

Mounting hole

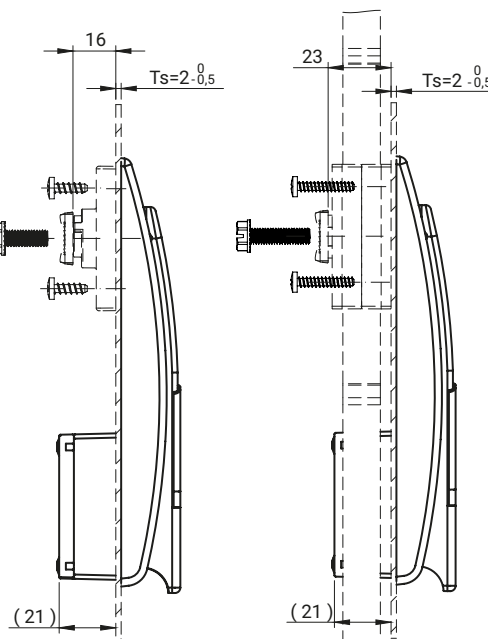

For a cap [N]

For a cogwheel mechanism [M]



where:

Ts - the thickness of sheet steel

Accessories to be ordered separately:

- insert (shaped, patented) pg. :1C-1, 1C-2

Components for a cap [N]

- Cap pg. :1C-27
- Sleeve pg. :1C-27
- Cam 1-point, 2-point, 3-point (groups: 11, 13, 21, 31, 33) pg. : 1C-10 do 1C-18
- Rods pg. : 1C-4, 1C-5
- Rod guides pg. :1C-6, 1C-7

Components for a cogwheel mechanism [M]

- Cogwheel mechanism MZ2 / MZ3 pg. :1 C-30 to 1C-33
- Cam 1-point. (groups 11, 13) pg. : 1C-10, 1C-11
- Adapter pg. : 1C-27
- Flat bar pg. : 1C-34 to 1C-40
- Flat bar guides and supports pg. :1C-6, 8, 1C-11 to 1C-40

TYPE OF LOCK	COMPONENTS	MATERIAL	FINISH [C]	
			RAL9005	RAL7035
RS750.N RS750.M	Body, Handle,	Polyamide PA6 GF30	07	08

How to order:

Type of lock

Finish

RS750.M — [C]